

LVD/FLB/2/3C—LV 2-WAY UNDERGROUND LINK BOX (INSULATED)

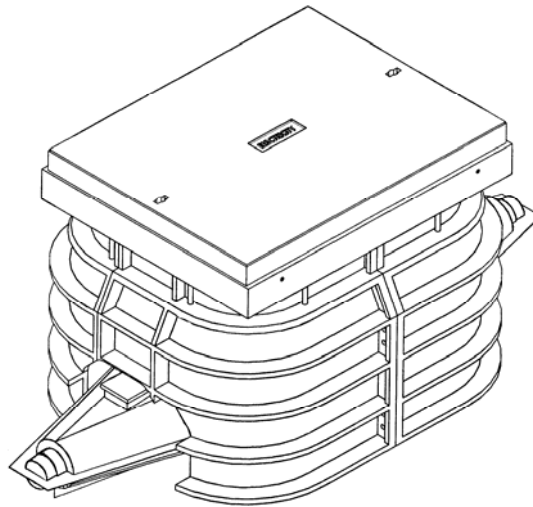

Application

LV 2 Way Underground Link Box (800 Amp Rated) for 70-300mm² 3 core CNE cable.

Features

- An all insulated 2 Way Link Box complete with height adjustable Grade B (12½ ton) pavement access assembly.
- High Density Polyethelene (HDPE) pavement access chamber supplied as standard eliminating the need for brick built constructions.
- The factory assembled and insulated turret will accommodate solid or fused (83mm crs) links to BS88.
- Traditional cast iron bell cover for reliable protection against water ingress (1 mtr head).
- Provision of approved neutral test facility and also generation/fault location connection point within the insulated turret.
- All the required phase and neutral/earth mechanical connectors are factory fitted and utilise the shear-head bolt technology to ensure consistent and reliable performance.
- Resin is not supplied, however, all sealing accessories are provided for the 'encapsulation' of the joint.

Product Testing

- ER C81/3 : Type Approval Tests for joints for 600/1000V cable systems
 - ESI Approved : Report N°: HED/015-185:300.
- BS EN 60947 Pt 1/3 : Low Voltage Switchgear and Control Gear
 - Section 8.3.3.3 : Temperature-rise
 - Section 8.3.3.5 : Making and breaking capacities
 - Report N°: TTR/210

Conversion Kit

- 4 Core Cable: Ref—LVD/FLB/2/CK
 - self assembly earth busbar with associated mechanical connectors

Accessories

- External Earth: Ref—LVD/FLB/4/EK
 - 70mm² earth bond assembly with associated bracketry, etc.
- Fuse Carriers: Part N° - 50097
- Solid Links: Part N° - 50093
- Lockable Manhole Cover
- Shroud Kit (for 'Live' Jointing)

LVD/FLB/2/3C

Product Features/Physical Dimensions

- Link Box Unit Assembly

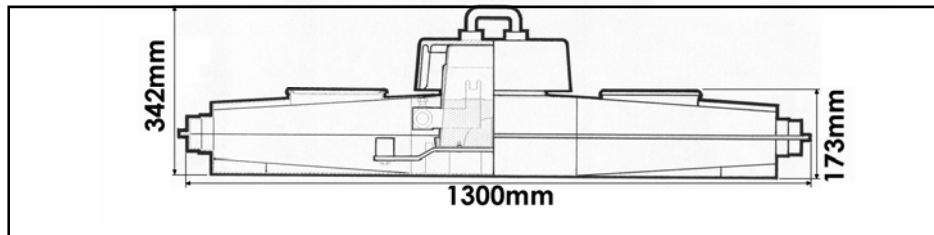

Resin Volume

- 30 litres

- Insulated Turret Assembly

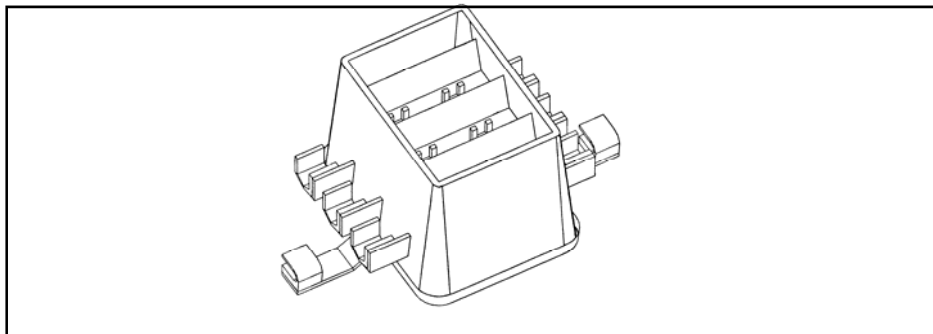

Turret

- Hi-Heat ABS (110°C temp withstand)
- 13 kg

- Bell Cover (Insulated - Optional)

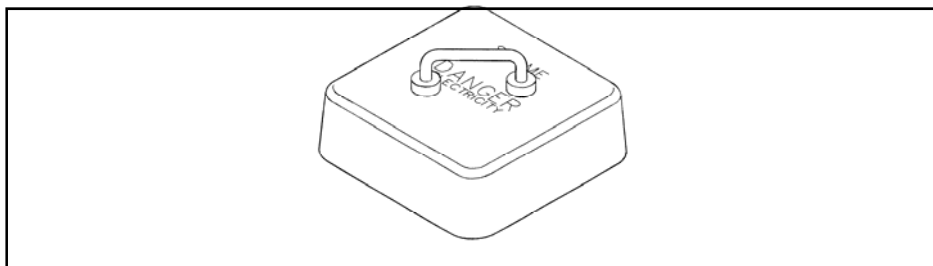

Weight

- 13 kg

Material

- Cast Iron

- Access Chamber Assembly (inc height adjustment and levelling kit)

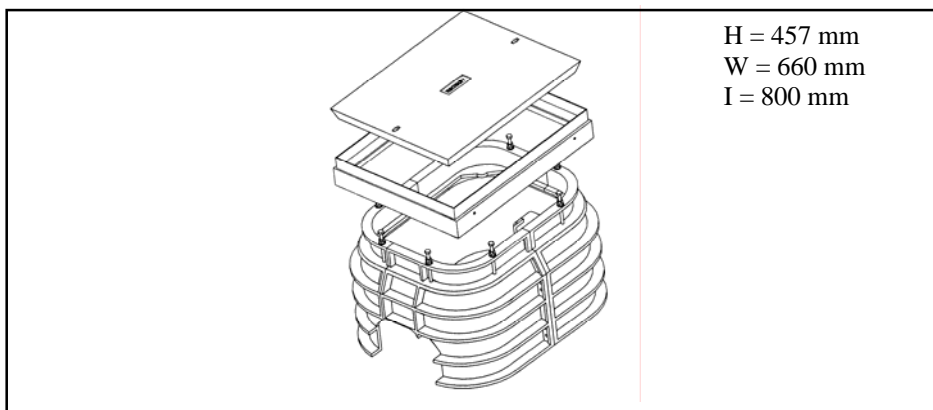

Manhole Cover

- Galvanised steel tray (concrete filled) 46 kg
- Galvanised steel frame 9.5 kg

Access Chamber

- High Density Polyethelene HDPE 15 kg